

AO RB-RS

AUTO-DUMPING
FORK MIXER FRENCH TYPE

MIXER
ART OF MIXING

PROFESSIONAL

AO RB Dumping on table (only left).

AO RS Dumping on divider (only left).

CAPACITY (LT)

- 230
- 330
- 440



AO RB-RS

AUTO-DUMPING FORK MIXER FRENCH TYPE

PROFESSIONAL

TECHNICAL FEATURES

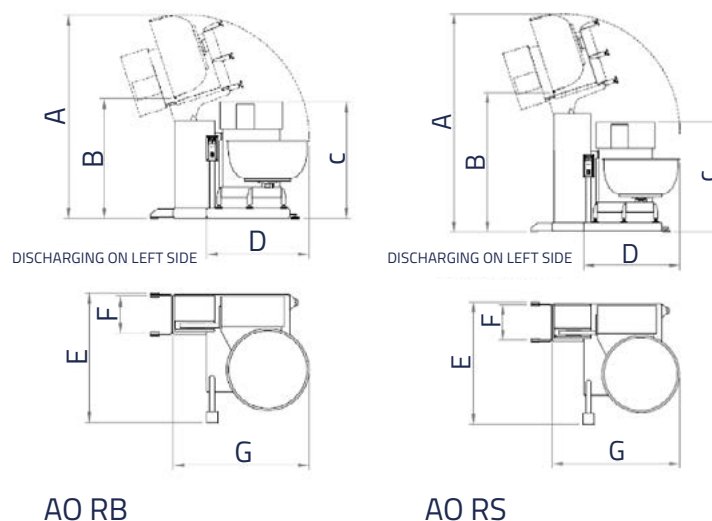

TECHNICAL DATA

MODEL		AO RB 230	AO RB 330	AO RB 440	AO RS 230	AO RS 330	AO RS 440
Dough capacity (min./max) *	kg	35/120	50/180	45/240	35/120	50/180	45/240
Flour capacity (min./max) *	kg	22/75	32/110	26/150	22/75	32/110	26/150
Water capacity (min./max) *	lt	13/45	18/70	18/90	13/45	18/70	18/90
Bowl volume	lt	230	330	440	230	330	440
% water/flour minimum	%	50	50	50	50	50	50
Spiral turns 1st / 2nd speed (50/60Hz)	rpm	47/70	47/70	47/70	47/70	47/70	47/70
Bowl turns 1st / 2nd speed (50/60Hz)	rpm	-/-	-/-	-/-	-/-	-/-	-/-
Motor power 1st / 2nd speed	kw	3.7/5.2	3.7/5.2	4.6/6.9	3.7/5.2	3.7/5.2	4.6/6.9
Current drawn V 230	A	19	19	26	19	19	26
Current drawn V 400	A	11	11	14.7	11	11	14.7
Total height (machine during discharging phase)	A mm	2330	2410	2500	2580	2660	2810
Height from bowl edge (machine during discharging phase)	B mm	1380	1360	1330	1636	1610	1650
Total height (machine to the ground)	C mm	1340	1340	1530	1340	1340	1530
Total width (machine during discharging phase)	D mm	1086	1175	1250	1086	1175	1250
Total depth	E mm	1480	1480	1650	1480	1480	1650
Depth from lateral support	F mm	420	460	460	420	460	460
Total width	G mm	1550	1633	1730	1550	1633	1730
Net weight	kg	850	890	1150	1050	1100	1320

*: capacity based on the percentage of liquid/flour = 60%

All data are to be considered as nominal, MIXER srl reserves the right to make any changes to the product and/or technical specifications without notice.

STANDARD FEATURES

- Painted steel structure.
- High-resistance aluminium fork that can be lifted manually.
- Stainless steel bowl.
- Two-speed fork motor.
- Movement transmitted by pulleys and V-belts with gear motor in oil bath.
- Adjustable mechanical brake on bowl.
- Electrical commands on the side of the head, with two timers. Setting of work time with automatic shift from 1st to 2nd speed.
- Closed rotating guard.
- Auto-dumping on table (1.2 m) on left (AO RB).
- Auto-dumping on divider (1.7 m) on left (AO RS).
- Hydraulic lifting system.
- Impulse button to rotate bowl for removing the product in the lifter push-buttons.
- Dumping control with hold-to-run buttons.

ON REQUEST

- Stainless steel fork.
- Special frequency/voltage 230/50/3 - 220/60/3 - 380/60/3.
- Wooden crate packaging.